

TOOLS

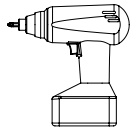

Impact Drill



#3 Phillips Bit

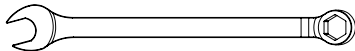

3/8" Open Ended Wrench

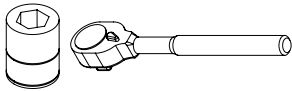

7/16" Socket & Wrench

PARTS & HARDWARE LIST



Tabletop
(3)



Adjustable Foot Kit
(3)

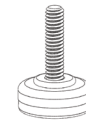

Leveling Glide
(3)



Rubber Grommet
(3)



Hex Nut
(36)



Washer
(36)

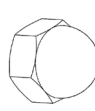

Acorn Nut
(36)



Air Purifier
(1)

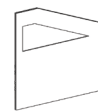

PET Divider
(3)



Steel Top Support
(3)

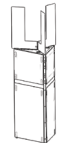

CORE Unit
(1)

ASSEMBLY STEPS

ASSEMBLING THE CORE UNIT

1. Assemble the three middle panels with hex nuts and lock washers. The middle panels all have two large access windows located on them. Leave hex nuts loose until all panels have been assembled.

2. Install the bottom triangle panel with cutout and top triangle panel with hex nuts and lock washers. Install the three leveling glides into bottom panel. Install the three rubber grommets into top triangle panel.

3. Connect all three top panels together using painted acorn nuts. Fit the assembly onto triangle top panel and secure unit with additional hex nuts and lock washers. Tighten all 36 hex nuts. Hang the outer sheet metal panels using lift and drop cleat on backs of panels. Place the assembly in desired location and level the completed unit with the leveling glides.

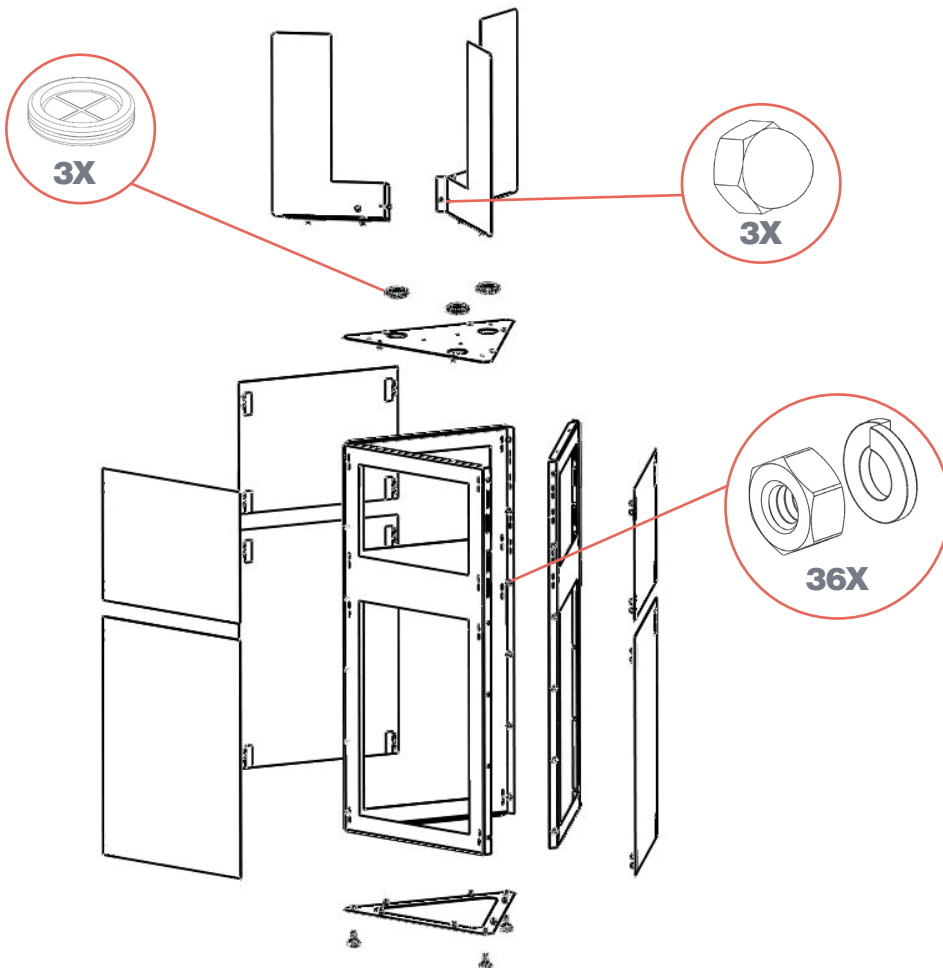

FOR MISSING PARTS OR QUESTIONS, PLEASE CALL CUSTOMER SERVICE AT 888-705-0777.

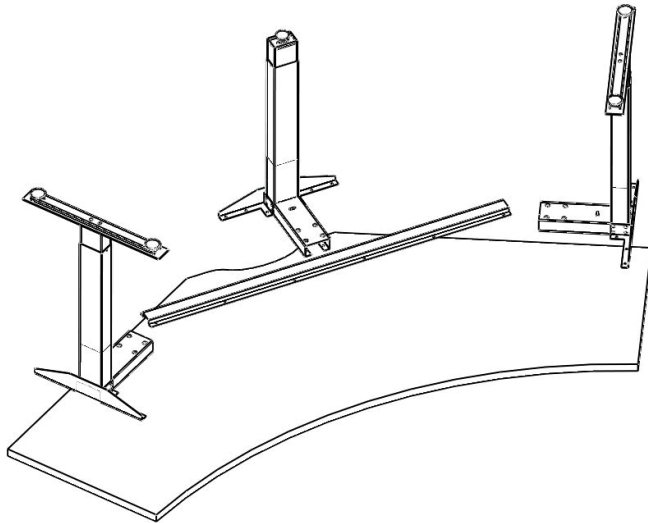

ASSEMBLING THE TABLES

4. Attach all three leg assemblies using the hardware supplied with the leg kits. Utilize the pre-drilled holes in the bottom of the tabletop to align and secure leg assemblies. Attach the support bar centered between two outer legs.

INSTALLING THE DIVIDERS

5. Install divider panel utilizing the cleats on the back edge of the divider panel. Set the cleats of the divider panel into the holes of the core unit and lower the panel to set in place.

6. Set the tables into place around the core unit, and level the tables leveling glides located on the feet.

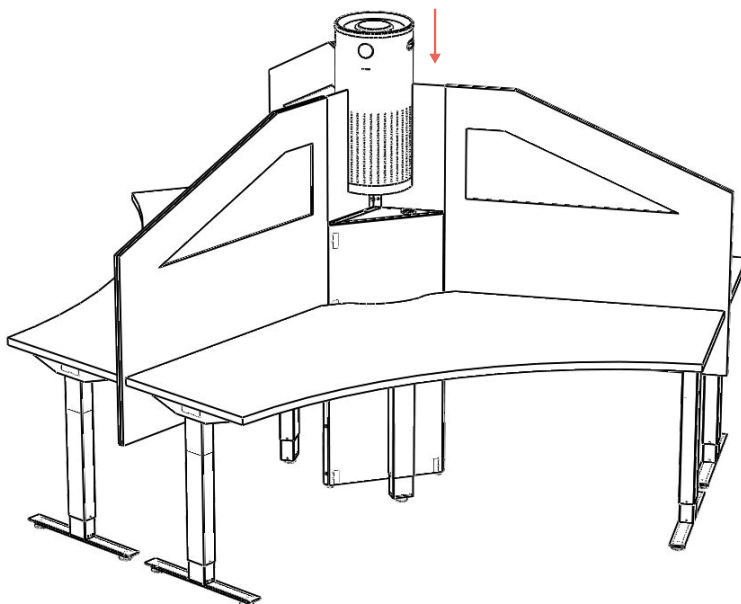
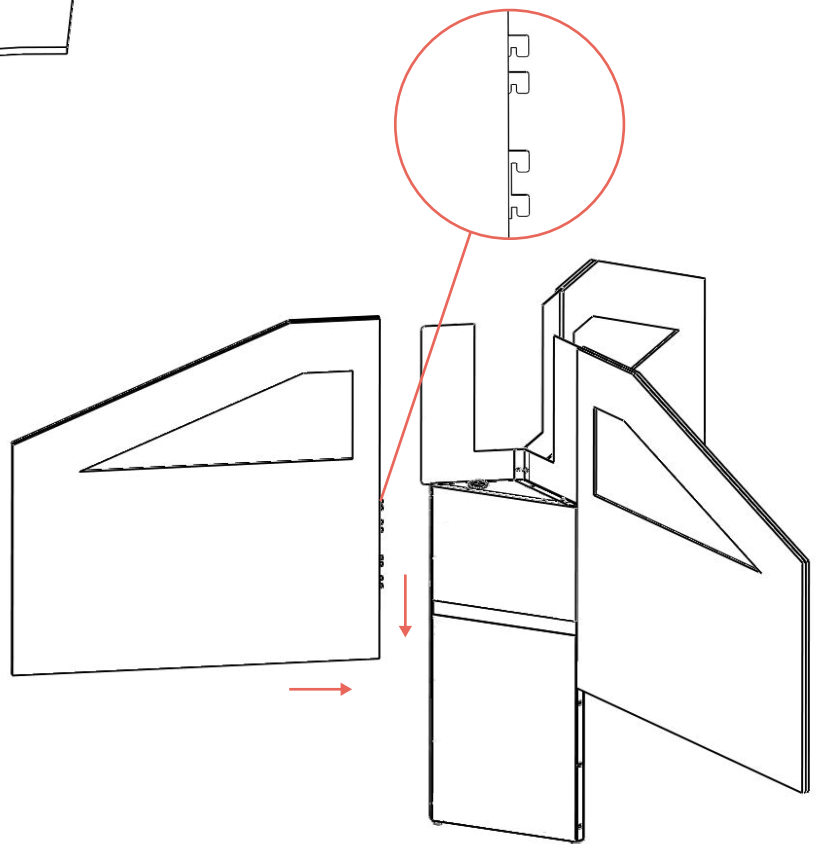

MOUNTING THE AIR PURIFIER

7. From the top, lower the air purifier onto the CORE unit. The power cord can be run through the grommets on the shelves of the core unit.