

## Fixed Height Table Assembly Instructions

### Parts Included:

1. Column (2)
2. Foot (2)
3. Hardware:
  - Phillips bolts (8)
  - Screws (16)
4. Table top
5. Table stiffener (optional)
6. Casters (optional)

### Tolls Needed:

- Phillips screw driver or impact drill  
 #Phillips bit (for impact drill)  
 (13mm wrench for optional casters)  
 Safety glasses

**If you are missing parts or have any questions, please call Customer Service at 888-705-0777.**

### Instructions

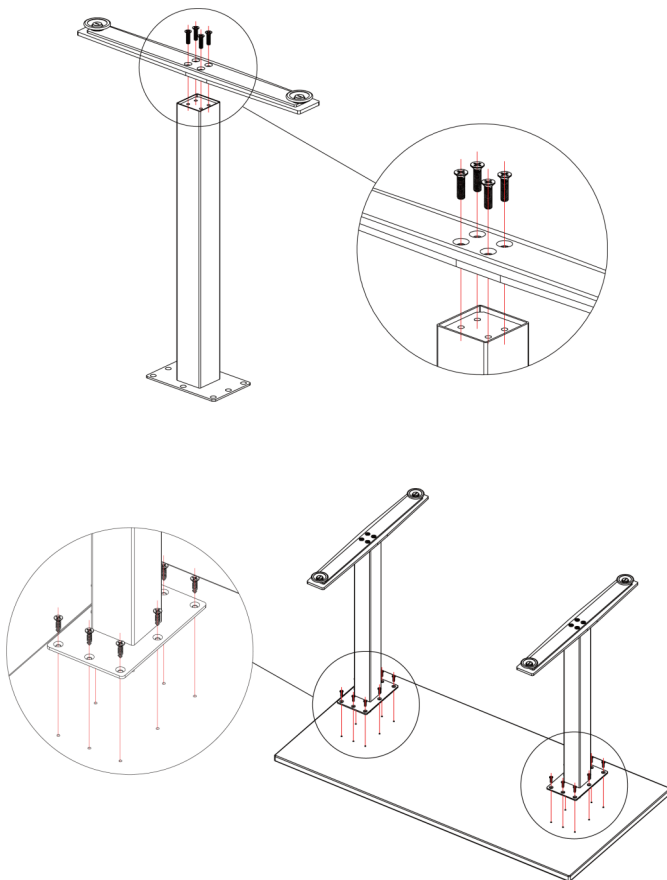

1. Set mounting plate on the floor with the bottom of the column facing up. Place the foot over the column lining up the holes in the foot and the column. Insert (4) Phillips bolts through the foot and into the column. Start bolts by hand to prevent cross threading.
  2. Use either screwdriver or impact drill to **tighten bolts as much as possible**. Assemble the second base.
  3. Lay the table top upside down on a cardboard or carpet and align the mounting plates with the pre-drilled holes. Use every hole in the mounting plate to attach the legs with the wood screws.
- NOTE: To install optional casters, remove leveling glides from the threaded inserts on bottom of the legs. Thread two caster stems instead. Use 13mm wrench to tighten the stems.**
4. If table stiffener is provided, attach it in the center of the table between the table legs.
  5. Turn the table over in the upright position. Using soft cloth, clean the top and the bases. Enjoy your table!



**START BOLTS BY HAND TO PREVENT CROSS THREADING**