

TOOLS



Impact Drill



#3 Phillips Bit



Safety Glasses

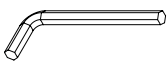

6 mm

PARTS & HARDWARE LIST

A	B	C	D	E	F	G	H	I	J	K
(12)	(2)	(12)	(2)	(2)	(2)	(20)	(1)	(1)	(1)	(1)
L	M	N								
(4)	(4)	(1)								



CAUTION

- PROPER ASSEMBLY REQUIRES TWO PEOPLE
- START BOLTS BY HAND TO PREVENT CROSS THREADING
- ASSEMBLE ON A SOFT & SMOOTH SURFACE TO PREVENT SURFACE DAMAGE
- LOCK WHEELS BEFORE LINKING TABLES TOGETHER

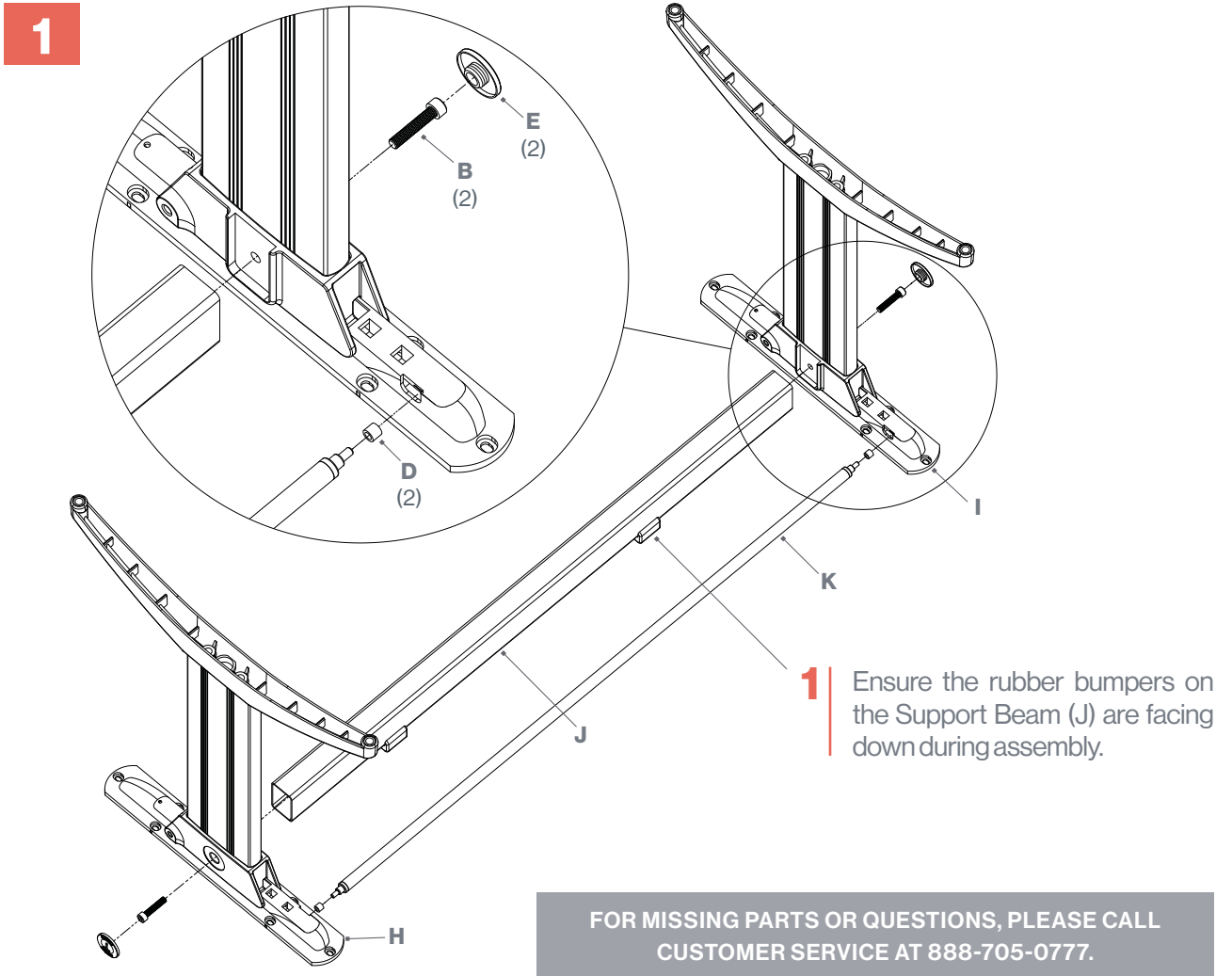

FOR MISSING PARTS OR QUESTIONS, PLEASE CALL CUSTOMER SERVICE AT 888-705-0777.



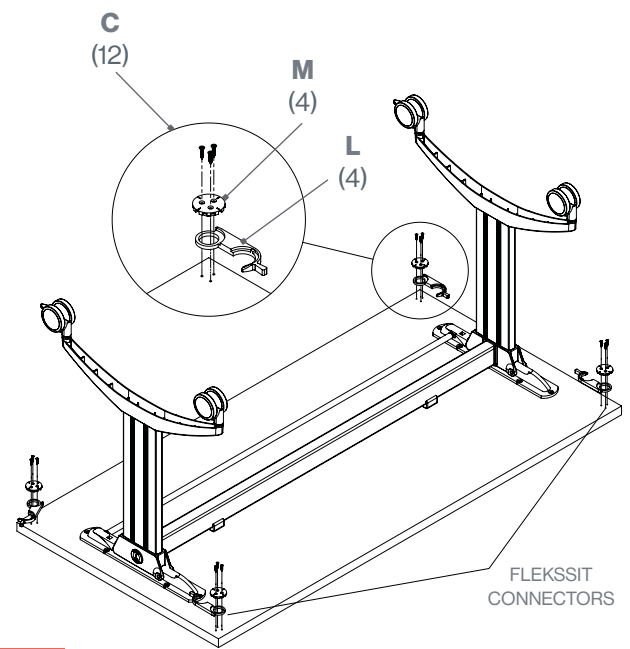
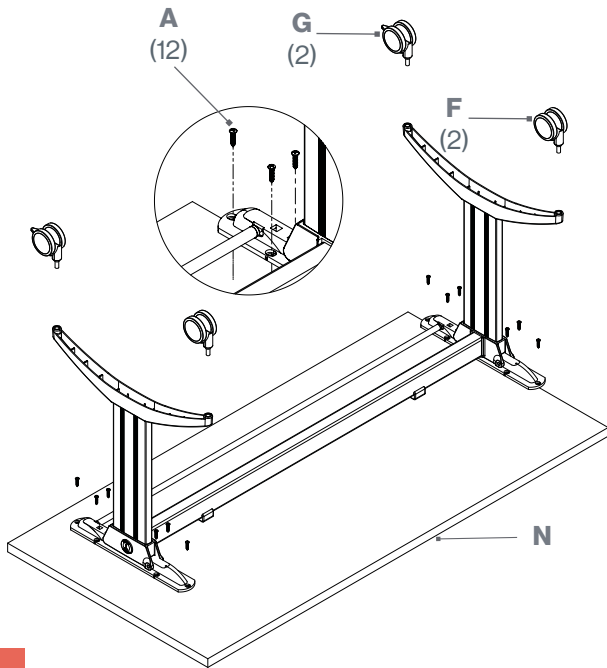

2

Install the locking casters (G) on the user side. The user side features the unlock bar (K).

3

Install the 4 Flekssit connectors (L & M) on the corners only. Additional pre-drilled locations are available for non-standard configurations.

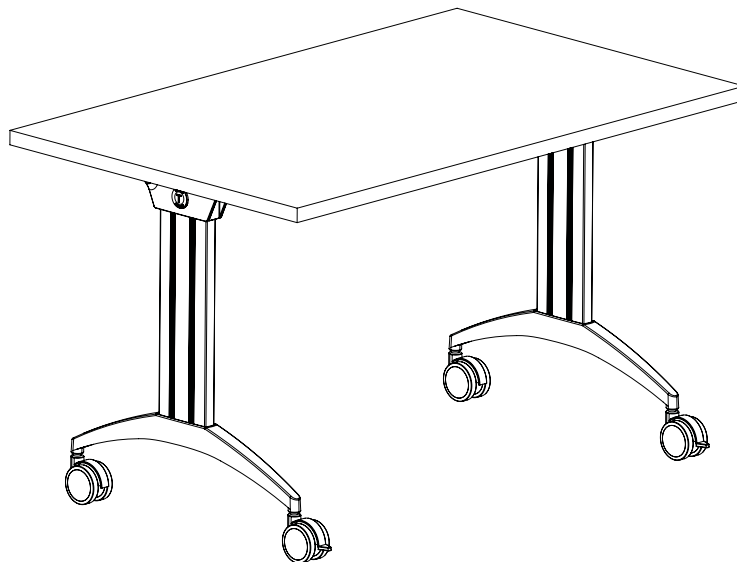

ASSEMBLED LINK FLIP & NEST TABLE

