





Kingston Table (Arched Legs) Assembly Instructions

Parts Included:

1. Column (2) 
2. Foot (2) 
3. Hardware:
Bolts (2)  Washer (2)  Screws (16) 
4. Table top (optional)
5. Table support (optional)

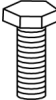
Tools Needed:

- 13mm ratchet wrench or impact drill
- 3/8" hex bit
- 13mm socket
- 13mm wrench (for optional casters)
- #3 Phillips bit
- Safety glasses

If you are missing parts or have any questions, please call Customer Service at 888.705-0777.

Instructions

Base Assembly

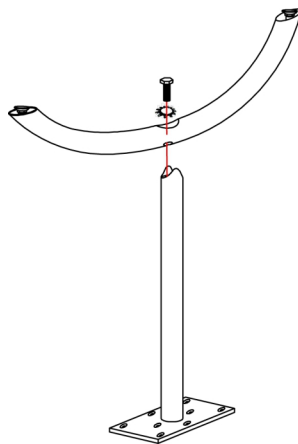

1. To assemble the bases, set mounting plate on the floor with the bottom of the column up. Place the foot over the column lining up the holes in the foot and the column. Insert (1) bolt and washer through the foot and into the column.
 2. Use either 13mm ratchet wrench or impact drill to tighten bolt as much as possible.
- CASTERS: if using optional casters, remove leveling glides from the threaded inserts on bottom of the legs. Thread two caster stems instead. Use 13mm wrench to tighten the caster stems.

Table Assembly

1. Lay table top upside down on cardboard or carpeted surface.
2. Position assembled legs at the edges and align mounting plates with pre-drilled holes in the top. Use every hole in the mounting plate to attach the legs with screws.
2. If table stiffener is provided, attach it in the center of the table between the legs.
3. Holding onto the edges of the top, carefully turn the table over in the upright position. Enjoy your table!



START BOLTS BY HAND TO PREVENT CROSS THREADING

